

846T Wafer

847T Wafer

847Q Lugged

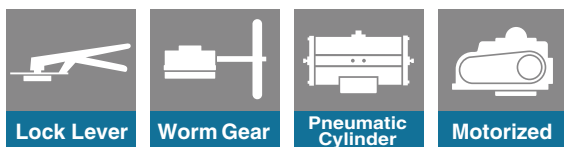
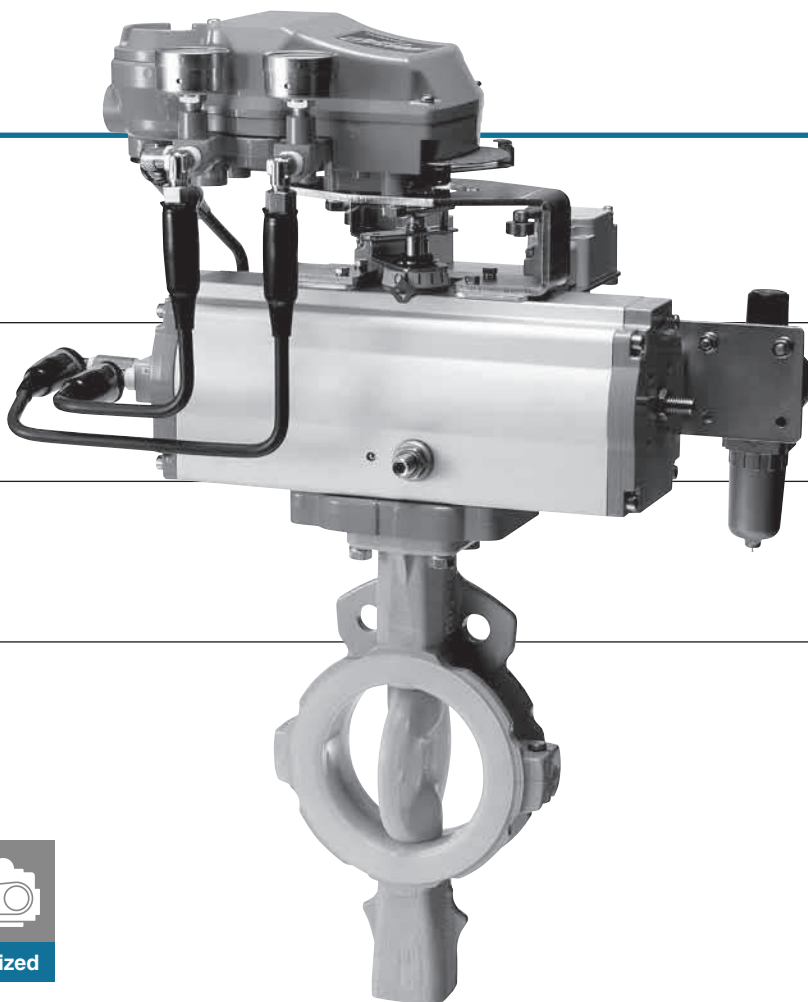

Features and Benefits

New design features of the TOMOE 847 series result in vastly improved sealing performance in applications where conditions are potentially hazardous.

High tension coil spring

(250, 300mm: coned disc spring)
Ensures a stable seal at both the upper and lower gland even at extreme temperatures or when thermal shock occurs.

Minimum 3mm PFA thickness

(250, 300mm: PTFE)
Seamfree PFA injection moulding (PTFE compression moulding) on the seat and disc to a minimum thickness of 3mm prevents permeation of dangerous fluids or gases.

No special gasket needed

Stable flange sealing performance is ensured by concentric circular grooves on the flange faces thereby eliminating the need for a special gasket when operating under specified temperatures.
The wider sealing area also ensures minimum "creep" at high temperatures.
Flange sealing mechanism is independent of the seating and gland seals which ensures there is no loss of line fluid.
Soft gaskets can be used when fitting the valve in the pipeline.

Total sealing

Valve structure includes primary, secondary and independent tertiary seal, ie. gland packing. There is also a fourth seal of O-rings on the top/bottom stems, ie. dust seal.

Lining

(50~200mm: PFA, 250~300mm: PTFE)
Seamless construction of the valve lining of the 847 Series ensures complete stability in all conditions.
Design and construction of conventional valves often means permeation of fluids or gases, particularly at high temperatures. By employing an injection moulding method and utilising the properties of PFA, PTFE at a minimum thickness of 3mm, the 847 Series is able to eliminate faults common to PTFE-lined valves of conventional design.

Pressure-Temperature Leakage Chart

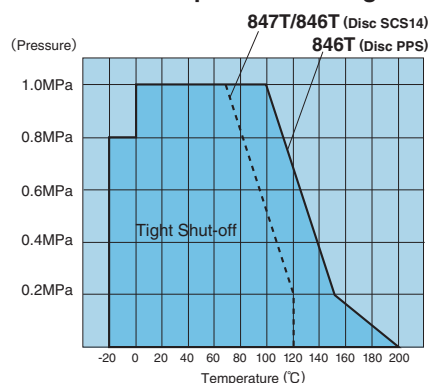

General Description

Chemically resistant butterfly valves. The unique construction of the TOMOE 847 Series provides superior strength and sealing properties essential in applications where conditions are potentially hazardous.

Sealing Properties

The upper and lower stem housings of the 847 Series valve have the same length high tension coil springs which provide stable sealing performance in cases of temperature change. Conventional valves usually employ a shorter spring in the lower stem housing. This can lead to a loading imbalance on the seat making it difficult to maintain consistent sealing performance.

The sealing design features a triple acting sealing mechanism controlled by the balanced spring forces. (250, 300mm: Coned disc springs).

In addition, stem seal leakage caused by excessive pipe flange damping forces is eliminated because the stem seal arrangement and the pipe flange seal are totally independent.

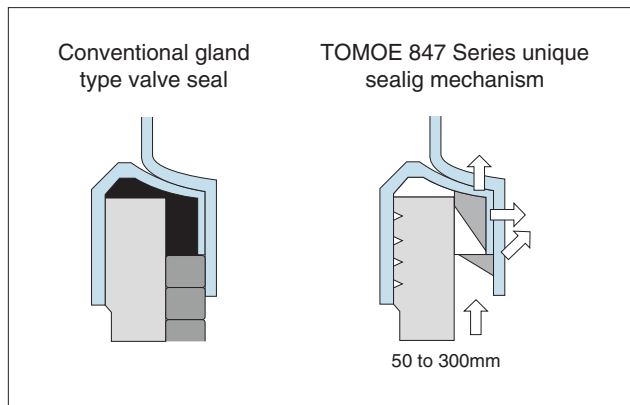
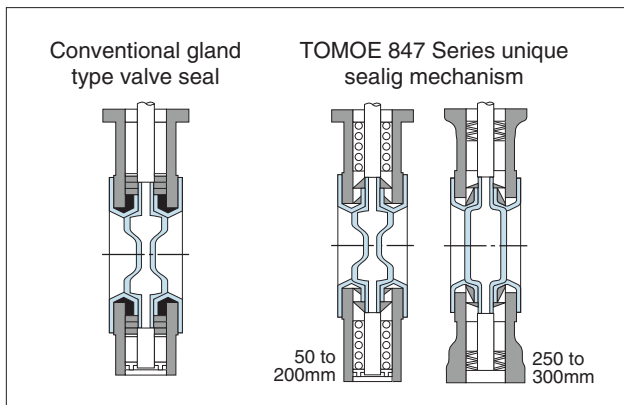
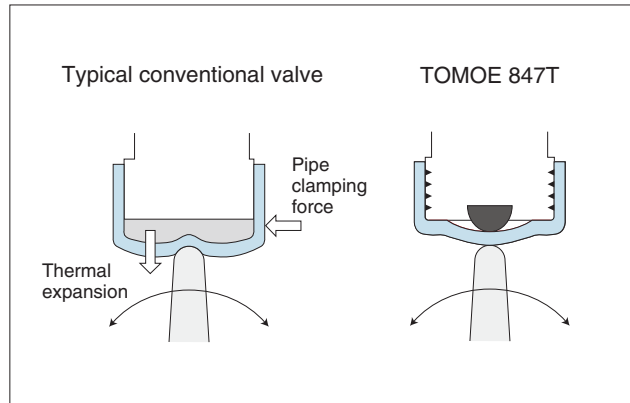

Butterfly Valve
TRITEC
TT2
334A
302A/303Q
304A/304Q
302Y/304Y
304M (HLV)
507V/508V
DTM
846T/847T/847Q
841T/842T
700Z
700G/704G/705G
700GB
731P/732P/731Q/732Q
71LG
700E/700K/700S
704G/722F/720F
KRV
227P
907H/908H (MKT)
903C

Standard Specifications

Type	846T	847T
Valve nominal size	65 to 300mm (8 sizes)	50 to 300mm (9 sizes)
Applicable flange standard	JIS 5K/10K, ANSI 125 lb/150 lb, ISO 7005-1 PN 6/10/16, BS10 Table E, DIN 2632 NP 6/10/16, BS 4504 PN 6/10/16	
Face-to-face dimensions	JIS B 2002 46 series/ ISO 5752 wafer butterfly valves (short)	
Max. working pressure *1	1.0 MPa	
Body shell test	1.5 MPa	
Seat leak test	1.1 MPa	
Working temperature range	PPS disc: -20 to 120 degrees C Stainless disc: -20 to 200 degrees C	-20 to 200 degrees C
Working temperature in continuous use *1	PPS disc: 0 to 80 degrees C Stainless disc: 0 to 150 degrees C	0 to 150 degrees C
Standard materials	Body	Ductile iron, FCD-S (A395)
	Disc	PPS (65 to 200mm) SCS14 (CF8M) 50 to 200mm: SCS13(CF8) with PFA lining 250, 300mm: SCS 13 (CF8) with PTFE lining
	Stem	SUS329J1 420J2SS
	Seat ring	PFA (Backup rubber: Fluorocarbon rubber) 50 to 200mm: PFA/250, 300mm: PTFE (Backup rubber: Fluorocarbon rubber)

*1 "Working temperature in continuous use" stands for the temperature continuously kept exceeding one hour.

846T/847T (Wafer)/847Q (Lugged)

846T/847T Expanded view of components

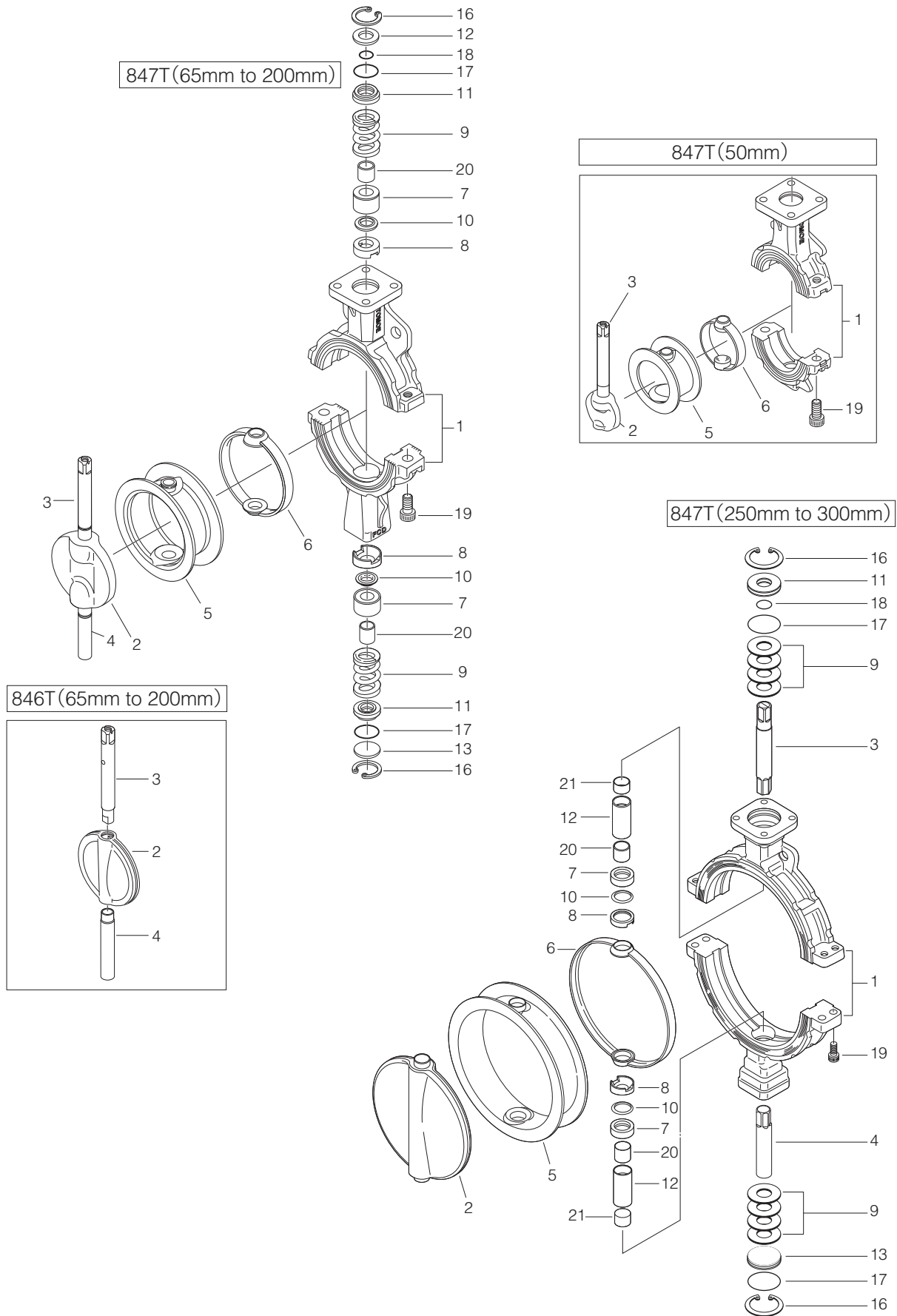

846T/847T Parts list

■ 846T/847T Parts list (846T: 65 to 200mm, 847T: 50 to 200mm)

No.	Description	Q'ty	Remarks
1	Body	1	
★ 2	Disc	1	
★ 3	Upper stem	1	
★ 4	Lower stem	1	
★ 5	Seat ring	1	See Remark 2.
★ 6	Back-up rubber	1	See Remark 2.
7	Bearing	1	50mm
		2	65mm to 200mm
8	Secondary ring	1	50mm
		2	65mm to 200mm
9	Spring	1	50mm
		2	65mm to 200mm
★ 10	Gland packing	1	50mm
		2	65mm to 200mm
11	Dust seal	1	50mm
		2	65mm to 200mm
12	Retaining spring	1	
13	Bottom cover	1	65mm to 200mm
16	C- ring	1	50mm
		2	65mm to 200mm
★ 17	O-ring	1	50mm
		2	65mm to 200mm
★ 18	O-ring	1	
19	Hexagon hole bolt	2	50mm to 150mm
		4	200mm
20	Bearing	1	50mm
		2	65mm to 200mm

■ 847T Parts list (250mm, 300mm)

No.	Description	Q'ty	Remarks
1	Body	1	
★ 2	Disc	1	
3	Upper stem	1	
4	Lower stem	1	
★ 5	Seat ring	1	
★ 6	Back-up rubber	1	
7	Bearing	2	
8	Secondary ring	2	
9	Spring	8	
★ 10	Gland packing	2	
11	Dust seal	1	
12	Bearing	2	
13	Bottom cover	1	
16	C- ring	2	
★ 17	O-ring	2	
★ 18	O-ring	1	
19	Hexagon hole bolt	2	250mm
		4	300mm
20	Bearing	2	
21	Bearing	2	

Remark 1: The ★ indicates recommended spare parts. They are supplied as "Seat ring set" with a small hexagonal spanner to remove set screws.

Remark 2: Item number 5 (seating) and 6 (Back-up rubber) are supplied as a set. For 847T type, item number 2 (disc), 3 (upper stem) and 4 (lower stem) are supplied as an assembled unit.

Butterfly Valve
TRITEC
TT2
334A
302A/303Q
304A/304Q
302Y/304Y
304M (HLV)
507V/508V
DTM
846T/847T/847Q
841T/842T
700Z
700G/704G/705G
700GB
731P/732P/731Q/732Q
71LG
700E/700K/700S
704G/722F/720F
KRV
227P
907H/908H (MKT)
903C

846T/847T (Wafer)/847Q (Lugged)

847T Actuator selection chart

847T

Model	Category	Size ($\frac{mm}{inch}$)									
		50	65	80	100	125	150	200	250	300	
		2	2 1/2	3	4	5	6	8	10	12	
1T	Standard	1T-1			1T-2		1T-3				
	Heavy duty	1T-1			1T-2		1T-3				
2U	Standard	2U-1		2U-2			2U-3		2U-4		
	Heavy duty	2U-1		2U-2			2U-3		2U-4		
7E, 3A	Standard	T85		T200		T380		T750		TGA-125	
	Heavy duty	T85		T200		T380		T750		TGA-125	
7G,7F 3U,3K	Standard	T200S		T380S		T750S		TG-10S		TG-12S	
	Heavy duty	T200S		T380S		T750S		TG-10S		TG-14S	
4 I	Standard	4 I-0		4 I-1		4 I-2		4 I-2.5		4 I-3	
	Heavy duty	4 I-0		4 I-1		4 I-2		4 I-2.5		4 I-3	
4J	Standard	SRJ-010			SRJ-020		SRJ-060				
	Heavy duty	SRJ-010			SRJ-020		SRJ-060				

Selection criteria	Standard	Select when none of the following heavy duty items apply.
	Heavy duty	Select when any of the following items apply. ① Working temperature is over 60 degrees C ② Powder or high viscosity fluids (consult us) ③ Velocity more than 3 m/s ④ Throttling ⑤ Slow travelling time of valve: more than 30 sec. ⑥ Dead end, pump outlet, emergency open

846T/847T Pressure-temperature rating

846T/847T (SCS14)

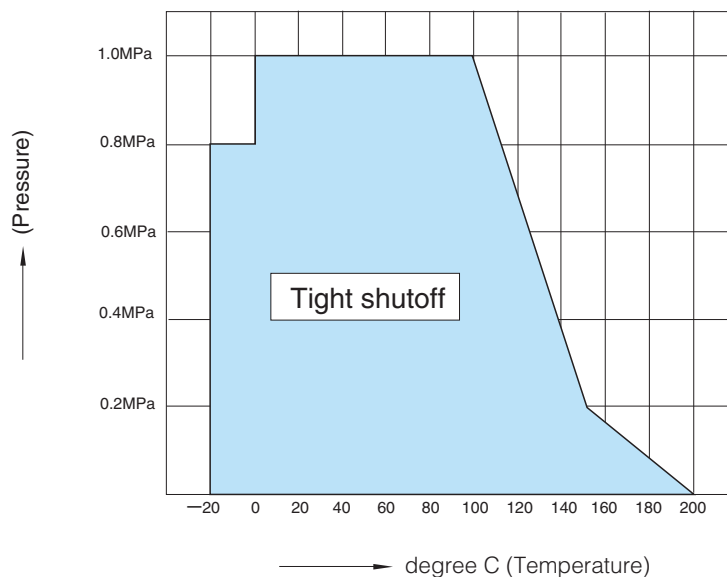

846T Actuator selection chart

846T

Model	Category	Size (mm/inch)							
		65	80	100	125	150	200	250	300
		2 1/2	3	4	5	6	8	10	12
1T	Standard	1T-1		1T-2		1T-3			
	Heavy duty								
2U	Standard	2U-1		2U-2		2U-3		2U-4	
	Heavy duty								
7E	Standard	T85		T200		T380		T750	
	Heavy duty								
7G, 7F 3U, 3K	Standard	T200S		T380S		T750S		TG-12S	
	Heavy duty							TG-10S TG-14S	
4 I	Standard	4 I-0		4 I-1		4 I-2		4 I-2.5	
	Heavy duty								
4J	Standard	SRJ-010		SRJ-020		SRJ-060			
	Heavy duty								

Selection criteria	Standard	Select when none of the following heavy duty items apply.
	Heavy duty	Select when any of the following items apply. ① Working temperature is over 60 degrees C ② Powder or high viscosity fluids (consult us) ③ Velocity more than 3 m/s ④ Throttling ⑤ Slow travelling time of valve: more than 30 sec. ⑥ Dead end, pump outlet, emergency open

Butterfly Valve
TRITEC
TT2
334A
302A/303Q
304A/304Q
302Y/304Y
304M (HLV)
507V/508V
DTM
846T/847T/847Q
841T/842T
700Z
700G/704G/705G
700GB
731P/732P/731Q/732Q
71LG
700E/700K/700S
704G/722F/720F
KRV
227P
907H/908H (MKT)
903C

846T Pressure-temperature rating

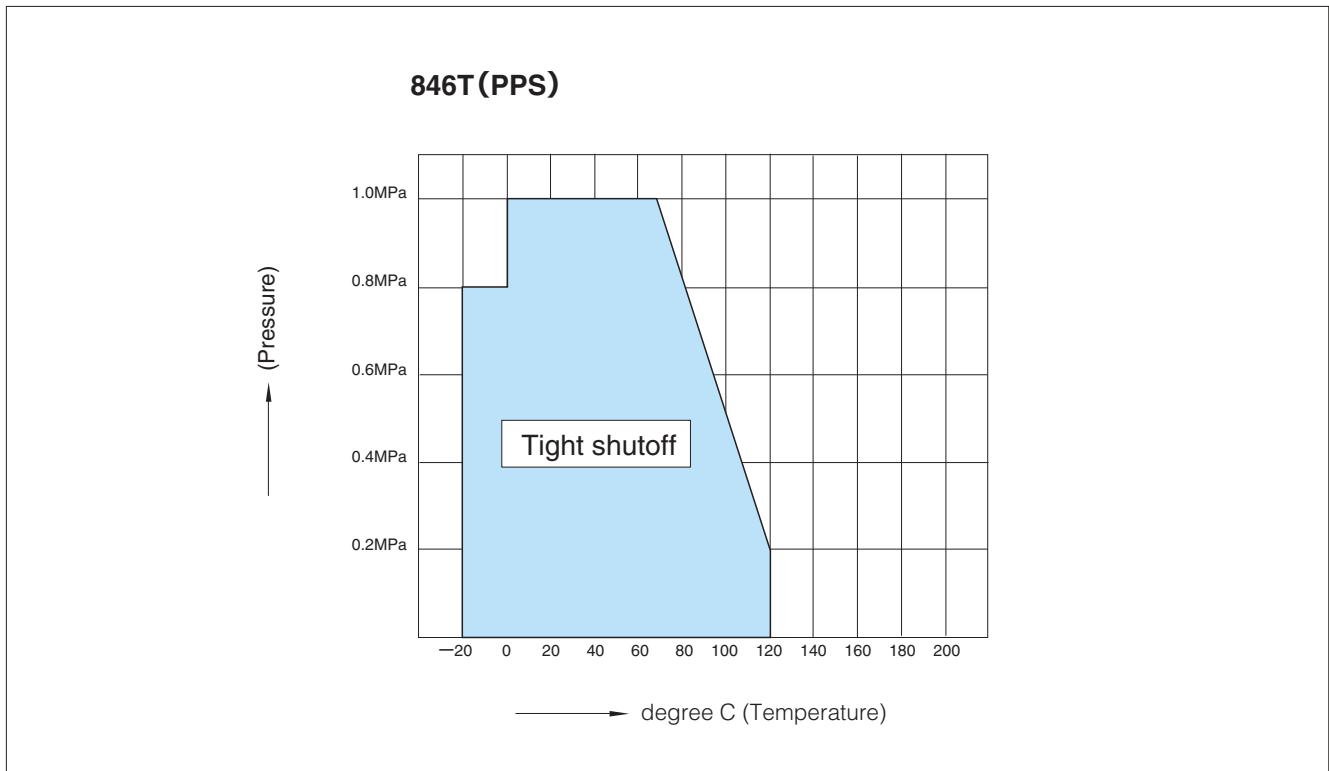

846T/847T (Wafer)/847Q (Lugged)

847T Wafer type

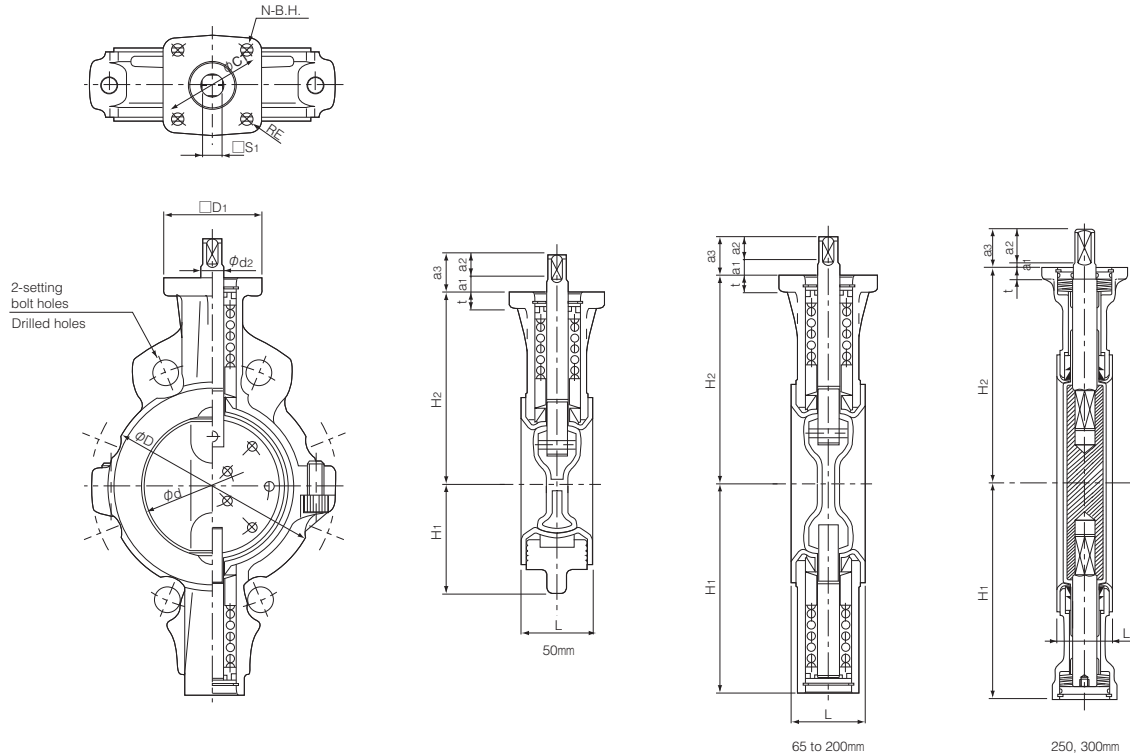

■ Dimensions

Nominal size		Dimension (mm)																	Approx. Mass (kg)
mm	inch	ϕd	ϕD	L	H_1	H_2	d_2	a_1	a_2	a_3	S_1	D_1	t	RE	ϕC_1	N	B.H.		
50	2	53.4	96	43	62	118.5	14	11	12	23	12	70	12	10	70	4	9	2.2	
65	2 1/2	67	115	46	125	125	14	11	12	23	12	70	12	10	70	4	9	3.3	
80	3	82	131	46	132.5	132.5	14	11	12	23	12	70	12	10	70	4	9	3.6	
100	4	102	152	52	148	148	16	11	17	28	14	70	12	10	70	4	9	5	
125	5	127.6	190	56	171	171	18	11	17	28	14	102	14	23.5	102	4	11	8.5	
150	6	151.6	217	56	183	183	18	11	17	28	14	102	14	23.5	102	4	11	10.1	
200	8	197	266	60	220	220	22	10	21	31	18	102	14	23.5	102	4	11	14.6	
250	10	247.5	320	68	260	260	28	5	30	35	24	102	14	24	102	4	11	28	
300	12	296.4	374	78	297	297	30	5	30	35	24	125	16	32	125	4	13	38	

847Q Lugged type

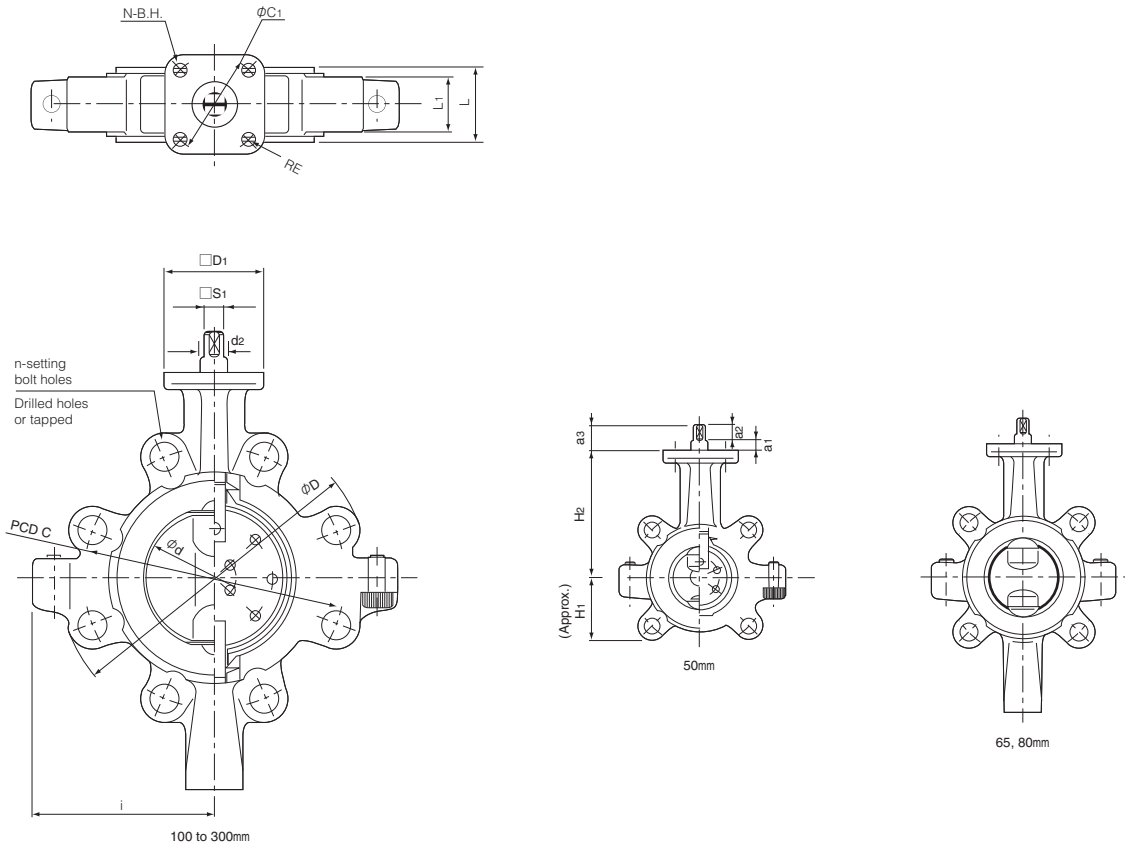

■ Dimensions

Nominal size		Dimension (mm)																		Approx. Mass (kg)
mm	inch	ϕd	ϕD	L	L_1	H_1	H_2	i	d_2	a_1	a_2	a_3	S_1	D_1	t	RE	ϕC_1	N	B.H.	
50	2	150.6	53.4	43	32	58	118.5	80	14	11	12	23	12	70	12	10	70	4	9	3.3
65	2 1/2	175	67	46	34	125	125	86	14	11	12	23	12	70	12	10	70	4	9	4.4
80	3	184	82	46	34	132.5	132.5	90	14	11	12	23	12	70	12	10	70	4	9	4.7
100	4	223	102	52	40	148	148	130	16	11	17	28	14	70	12	10	70	4	9	8.6
125	5	252	127.6	56	43	171	171	150	18	11	17	28	14	102	14	23.5	102	4	11	12.6
150	6	276	151.6	56	44	183	183	163	18	11	17	28	14	102	14	23.5	102	4	11	13.3
200	8	331	197	60	50	220	220	180	22	10	21	31	18	102	14	23.5	102	4	11	21.3
250	10	406	247.5	68	52	260	260	242	28	5	30	35	24	102	14	24	102	4	11	37
300	12	476	296.4	78	66	297	297	270.5	30	5	30	35	24	125	16	32	125	4	13	54

Butterfly Valve

TRITEC

TT2

334A

302A/303Q

304A/304Q

302Y/304Y

304M (HLV)

507V/508V

DTM

846T/847T/847Q

841T/842T

700Z

700G/704G/705G

700GB

731P/732P/731Q/732Q

71LG

700E/700K/700S

704G/722F/720F

KRV

227P

907H/908H (MKT)

903C

846T/847T (Wafer)/847Q (Lugged)

Lock lever type 847T-1T(50mm to 200mm) / 846T-1T(65mm to 200mm)

847T-1T

Nominal size		Dimension (mm)							Lever type	Approx. Mass (kg)
mm	inch	ϕd	ϕD	L	H ₁	H ₂	H ₃	W		
50	2	53.4	96	43	62	118.5	66	200	1T-1	2.8
65	2 1/2	67	115	46	125	125	66	200	1T-1	3.9
80	3	82	131	46	132.5	132.5	66	200	1T-1	4.2
100	4	102	152	52	148	148	66	200	1T-1	5.6
125	5	127.6	190	56	171	171	92	300	1T-2	9.8
150	6	151.6	217	56	183	183	92	300	1T-2	11.4
200	8	197	266	60	220	220	97	350	1T-3	16.3

846T-1T

Nominal size		Dimension (mm)							Lever type	Approx. Mass (kg)
mm	inch	ϕd	ϕD	L	H ₁	H ₂	H ₃	W		
65	2 1/2	67	115	46	125	125	66	200	1T-1	3.9
80	3	82	131	46	132.5	132.5	66	200	1T-1	4.3
100	4	102	152	52	148	148	66	200	1T-1	5.7
125	5	127.6	190	56	171	171	92	300	1T-2	9.8
150	6	151.6	217	56	183	183	92	300	1T-2	11.4
200	8	197	266	60	220	220	97	350	1T-3	16

846T/847T-1T

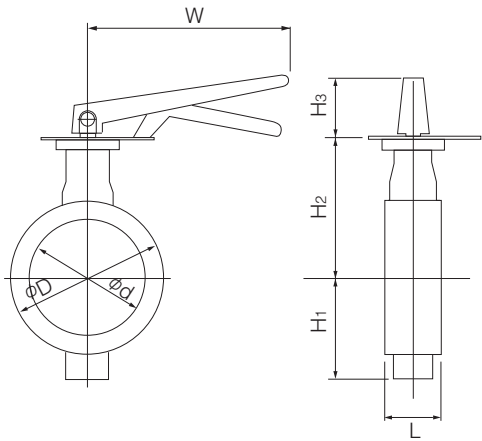

Worm gear type 847T-2U(50mm to 300mm) / 846T-2U(65mm to 300mm)

■847T-2U

Nominal size		Dimension (mm)										Gear type	Approx. Mass (kg)
mm	inch	ϕd	ϕD	L	H ₁	H ₂	H ₃	E	K	F	W		
50	2	53.4	96	43	62	118.5	29.5	36	46	160	100	2U-1	4.5
65	2 1/2	67	115	46	125	125	29.5	36	46	160	100	2U-1	5.6
80	3	82	131	46	132.5	132.5	29.5	36	46	160	100	2U-1	5.9
100	4	102	152	52	148	148	34.5	44	53	173.5	160	2U-2	9.2
125	5	127.6	190	56	171	171	34.5	44	53	173.5	160	2U-2	12.7
150	6	151.6	217	56	183	183	34.5	44	53	173.5	160	2U-2	14.3
200	8	197	266	60	220	220	41.5	67	75	198	200	2U-3	22.2
250	10	247.5	320	68	260	260	41.5	67	75	198	200	2U-3	36
300	12	296.4	374	78	297	297	48	87.5	90	222.5	200	2U-4	52

■846T-2U

Nominal size		Dimension (mm)										Gear type	Approx. Mass (kg)
mm	inch	ϕd	ϕD	L	H ₁	H ₂	H ₃	E	K	F	W		
65	2 1/2	67	115	46	125	125	29.5	36	46	160	100	2U-1	5.6
80	3	82	131	46	132.5	132.5	29.5	36	46	160	100	2U-1	6
100	4	102	152	52	148	148	34.5	44	53	173.5	160	2U-2	9.3
125	5	127.6	190	56	171	171	34.5	44	53	173.5	160	2U-2	12.7
150	6	151.6	217	56	183	183	34.5	44	53	173.5	160	2U-2	14.3
200	8	197	266	60	220	220	41.5	67	75	198	200	2U-3	21.9
250	10	247.5	320	68	260	260	41.5	67	75	198	200	2U-3	36
300	12	296.4	374	78	297	297	48	87.5	90	222.5	200	2U-4	52

■846T/847T-2U

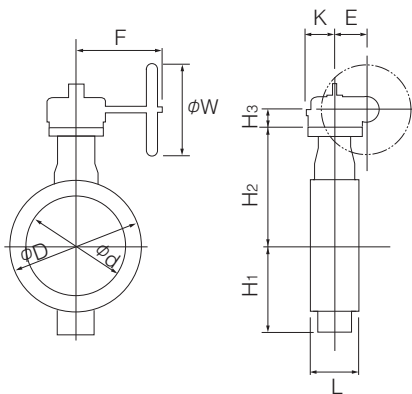

■2U Installation direction

2UA (standard)	2UAR	2UB	2UBR

Butterfly Valve
TRITEC
TT2
334A
302A/303Q
304A/304Q
302Y/304Y
304M (HLV)
507V/508V
DTM
846T/847T/847Q
841T/842T
700Z
700G/704G/705G
700GB
731P/732P/731Q/732Q
71LG
700E/700K/700S
704G/722F/720F
KRV
227P
907H/908H (MKT)
903C

846T/847T (Wafer)/847Q (Lugged)

Double-acting pneumatic cylinder type 847T-7E (50mm to 300mm)

847T-7E Standard

Nominal size		Dimension (mm)										Cylinder type	Approx. Mass (kg)
mm	inch	ϕd	ϕD	L	H ₁	H ₂	H ₃	A	P	f ₁	f ₂		
50	2	53.4	96	43	62	118.5	168	276	142	75	47	T85	8
65	2 1/2	67	115	46	125	125	168	276	142	75	47	T85	9
80	3	82	131	46	132.5	132.5	168	276	142	75	47	T85	9
100	4	102	152	52	148	148	203	346	176	79	57	T200	14
125	5	127.6	190	56	171	171	203	346	176	79	57	T200	17
150	6	151.6	217	56	183	183	203	346	176	79	57	T200	19
200	8	197	266	60	220	220	231	423	214	91	69	T380	30
250	10	247.5	320	68	260	260	269	546	270	118	85	T750	52
300	12	296.4	374	78	297	297	269	546	270	118	85	T750	62

847T-7E, 3A Heavy duty

Nominal size		Dimension (mm)										Cylinder type	Approx. Mass (kg)
mm	inch	ϕd	ϕD	L	H ₁	H ₂	H ₃	A	P	f ₁	f ₂		
50	2	53.4	96	43	62	118.5	168	276	142	75	47	T85	8
65	2 1/2	67	115	46	125	125	168	276	142	75	47	T85	9
80	3	82	131	46	132.5	132.5	168	276	142	75	47	T85	9
100	4	102	152	52	148	148	203	346	176	79	57	T200	14
125	5	127.6	190	56	171	171	203	346	176	79	57	T200	17
150	6	151.6	217	56	183	183	231	423	214	91	69	T380	25
200	8	197	266	60	220	220	231	423	214	91	69	T380	30
250	10	247.5	320	68	260	260	269	546	270	118	85	T750	52
300	12	296.4	374	78	297	297	269	754	373	167	100	TGA-125	81

847T-7E, 3A High Temperature Specification (For fluids over 100 degrees C)

Nominal size		Dimension (mm)										Cylinder type	Approx. Mass (kg)
mm	inch	ϕd	ϕD	L	H ₁	H ₂	H ₃	A	P	f ₁	f ₂		
50	2	53.4	96	43	62	118.5	243	276	142	75	47	T85	8
65	2 1/2	67	115	46	125	125	243	276	142	75	47	T85	9
80	3	82	131	46	132.5	132.5	243	276	142	75	47	T85	9
100	4	102	152	52	148	148	278	346	176	79	57	T200	14
125	5	127.6	190	56	171	171	278	346	176	79	57	T200	17
150	6	151.6	217	56	183	183	306	423	214	91	69	T380	25
200	8	197	266	60	220	220	331	423	214	91	69	T380	30
250	10	247.5	320	68	260	260	369	546	270	118	85	T750	52
300	12	296.4	374	78	297	297	359	754	373	167	100	TGA-125	81

7E,3A Installation direction

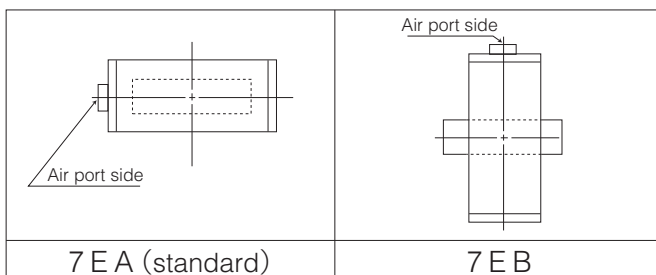

Selection criteria	Standard	Select when none of the following heavy duty items apply.
	Heavy duty	Select when any of the following items apply. ① Working temperature is over 60 degrees C ② Powder or high viscosity fluids (consult us) ③ Velocity more than 3 m/s ④ Throttling ⑤ Slow travelling time of valve: more than 30 sec. ⑥ Dead end, pump outlet, emergency open

Double-acting pneumatic cylinder type 846T-7E / 3A (65mm to 300mm)

■ 846T-7E Standard

Nominal size		Dimension (mm)										Cylinder type	Approx. Mass (kg)
mm	inch	ϕd	ϕD	L	H ₁	H ₂	H ₃	A	P	f ₁	f ₂		
65	2 1/2	67	115	46	125	125	168	276	142	75	47	T85	9
80	3	82	131	46	132.5	132.5	168	276	142	75	47	T85	9
100	4	102	152	52	148	148	203	346	176	79	57	T200	14
125	5	127.6	190	56	171	171	203	346	176	79	57	T200	17
150	6	151.6	217	56	183	183	203	346	176	79	57	T200	19
200	8	197	266	60	220	220	231	423	214	91	69	T380	29
250	10	247.5	320	68	260	260	269	546	270	118	85	T750	52
300	12	296.4	374	78	297	297	269	546	270	118	85	T750	62

■ 846T-7E/3A Heavy duty

Nominal size		Dimension (mm)										Cylinder type	Approx. Mass (kg)
mm	inch	ϕd	ϕD	L	H ₁	H ₂	H ₃	A	P	f ₁	f ₂		
65	2 1/2	67	115	46	125	125	168	276	142	75	47	T85	9
80	3	82	131	46	132.5	132.5	168	276	142	75	47	T85	9
100	4	102	152	52	148	148	203	346	176	79	57	T200	14
125	5	127.6	190	56	171	171	203	346	176	79	57	T200	17
150	6	151.6	217	56	183	183	231	423	214	91	69	T380	23
200	8	197	266	60	220	220	231	423	214	91	69	T380	29
250	10	247.5	320	68	260	260	269	546	270	118	85	T750	52
300	12	296.4	374	78	297	297	359	754	373	167	100	TGA-125	81

■ 846T-7E/3A High Temperature Specification (For fluids over 100 degrees C)

Nominal size		Dimension (mm)										Cylinder type	Approx. Mass (kg)
mm	inch	ϕd	ϕD	L	H ₁	H ₂	H ₃	A	P	f ₁	f ₂		
65	2 1/2	67	115	46	125	125	243	276	142	75	47	T85	9
80	3	82	131	46	132.5	132.5	243	276	142	75	47	T85	9
100	4	102	152	52	148	148	278	346	176	79	57	T200	14
125	5	127.6	190	56	171	171	278	346	176	79	57	T200	17
150	6	151.6	217	56	183	183	306	423	214	81	69	T380	23
200	8	197	266	60	220	220	331	423	214	81	69	T380	29
250	10	247.5	320	68	260	260	369	546	270	118	85	T750	52
300	12	296.4	374	78	297	297	369	754	373	167	100	TGA-125	81

Selection criteria	Standard	Select when none of the following heavy duty items apply.
	Heavy duty	Select when any of the following items apply. ① Working temperature is over 60 degrees C ② Powder or high viscosity fluids (consult us) ③ Velocity more than 3 m/s ④ Throttling ⑤ Slow travelling time of valve: more than 30 sec. ⑥ Dead end, pump outlet, emergency open

■ 846T/847T-7E/3A

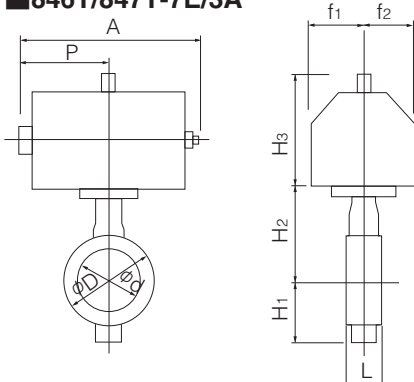

■ Caution for actuator mounting

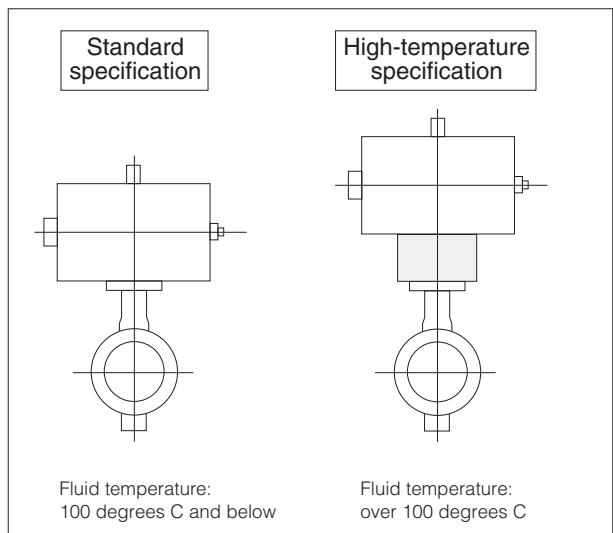

Butterfly Valve
TRITEC
TT2
334A
302A/303Q
304A/304Q
302Y/304Y
304M (HLV)
507V/508V
DTM
846T/847T/847Q
841T/842T
700Z
700G/704G/705G
700GB
731P/732P/731Q/732Q
71LG
700E/700K/700S
704G/722F/720F
KRV
227P
907H/908H (MKT)
903C

846T/847T (Wafer)/847Q (Lugged)

Single-acting pneumatic cylinder type 847T-7G (Air to open: 50mm to 200mm) / 847T-7F (Air to close: 50mm to 200mm)

847T-7G/7F Standard

Nominal size		Dimension (mm)										Cylinder type	Approx. Mass (kg)
mm	inch	ϕd	ϕD	L	H ₁	H ₂	H ₃	A	P	f ₁	f ₂		
50	2	53.4	96	43	62	118.5	203	449	226	79	57	T200S	13
65	2 1/2	67	115	46	125	125	203	449	226	79	57	T200S	14
80	3	82	131	46	132.5	132.5	203	449	226	79	57	T200S	15
100	4	102	152	52	148	148	231	550	276	91	69	T380S	24
125	5	127.6	190	56	171	171	231	550	276	91	69	T380S	28
150	6	151.6	217	56	183	183	269	723	360	118	85	T750S	43
200	8	197	266	60	220	220	269	723	360	118	85	T750S	47

847T-7G/7F Heavy duty

Nominal size		Dimension (mm)										Cylinder type	Approx. Mass (kg)
mm	inch	ϕd	ϕD	L	H ₁	H ₂	H ₃	A	P	f ₁	f ₂		
50	2	53.4	96	43	62	118.5	203	449	226	79	57	T200S	13
65	2 1/2	67	115	46	125	125	203	449	226	79	57	T200S	14
80	3	82	131	46	132.5	132.5	231	550	276	91	69	T380S	23
100	4	102	152	52	148	148	231	550	276	91	69	T380S	24
125	5	127.6	190	56	171	171	269	723	360	118	85	T750S	41
150	6	151.6	217	56	183	183	269	723	360	118	85	T750S	43

847T-7G/7F High Temperature Specification (For fluids over 100 degrees C)

Nominal size		Dimension (mm)										Cylinder type	Approx. Mass (kg)
mm	inch	ϕd	ϕD	L	H ₁	H ₂	H ₃	A	P	f ₁	f ₂		
50	2	53.4	96	43	62	118.5	278	449	226	79	57	T200S	13
65	2 1/2	67	115	46	125	125	278	449	226	79	57	T200S	16
80	3	82	131	46	132.5	132.5	306	550	276	91	69	T380S	24
100	4	102	152	52	148	148	306	550	276	91	69	T380S	26
125	5	127.6	190	56	171	171	344	723	360	118	85	T750S	45
150	6	151.6	217	56	183	183	344	723	360	118	85	T750S	46

Selection criteria	Standard	Select when none of the following heavy duty items apply.
	Heavy duty	Select when any of the following items apply. ① Working temperature is over 60 degrees C ② Powder or high viscosity fluids (consult us) ③ Velocity more than 3 m/s ④ Throttling ⑤ Slow travelling time of valve: more than 30 sec. ⑥ Dead end, pump outlet, emergency open

Single-acting Pneumatic Cylinder Type 846T-7G (Air to open: 65mm to 200mm) / 846T-7F (Air to close: 65mm to 200mm)

■ 846T-7G/7F Heavy Duty

Nominal size		Dimension (mm)										Cylinder type	Approx. Weight (kg)
mm	inch	ϕd	ϕD	L	H ₁	H ₂	H ₃	A	P	f ₁	f ₂		
65	2 1/2	67	115	46	125	125	203	449	226	79	57	T200S	14
80	3	82	131	46	132.5	132.5	203	449	226	79	57	T200S	15
100	4	102	152	52	148	148	231	550	276	91	69	T380S	24
125	5	127.6	190	56	171	171	231	550	276	91	69	T380S	28
150	6	151.6	217	56	183	183	269	723	360	118	85	T750S	43
200	8	197	266	60	220	220	269	723	360	118	85	T750S	47

■ 846T-7G/7F Heavy Duty

Nominal size		Dimension (mm)										Cylinder type	Approx. Weight (kg)
mm	inch	ϕd	ϕD	L	H ₁	H ₂	H ₃	A	P	f ₁	f ₂		
65	2 1/2	67	115	46	125	125	203	449	226	79	57	T200S	14
80	3	82	131	46	132.5	132.5	231	550	276	91	69	T380S	23
100	4	102	152	52	148	148	231	550	276	91	69	T380S	24
125	5	127.6	190	56	171	171	269	723	360	118	85	T750S	41
150	6	151.6	217	56	183	183	269	723	360	118	85	T750S	43

■ 846T-7G/7F High Temperature Specification (SCS14 Disc: For fluids over 100 degrees C)

Nominal size		Dimension (mm)										Cylinder type	Approx. Weight (kg)
mm	inch	ϕd	ϕD	L	H ₁	H ₂	H ₃	A	P	f ₁	f ₂		
65	2 1/2	67	115	46	125	125	278	449	226	79	57	T200S	16
80	3	82	131	46	132.5	132.5	306	550	276	91	69	T380S	24
100	4	102	152	52	148	148	306	550	276	91	69	T380S	26
125	5	127.6	190	56	171	171	344	723	360	118	85	T750S	45
150	6	151.6	217	56	183	183	344	723	360	118	85	T750S	46

■ 846T/847T-7F/7G

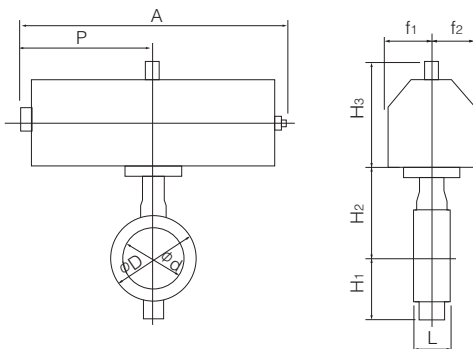

Selection criteria	Standard	Select when none of the following heavy duty items apply.
	Heavy duty	Select when any of the following items apply. ① Working temperature is over 60 degrees C ② Powder or high viscosity fluids (consult us) ③ Velocity more than 3 m/s ④ Throttling ⑤ Slow travelling time of valve: more than 30 sec. ⑥ Dead end, pump outlet, emergency open

■ 7F/7G Installation Direction

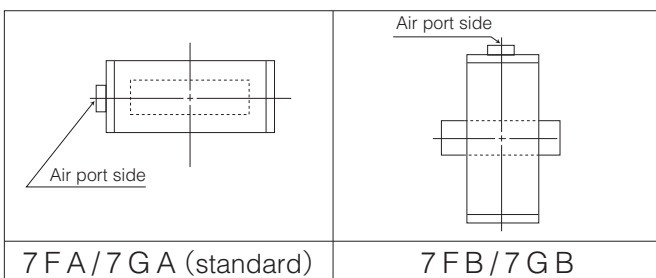

■ Caution for Actuator Mounting

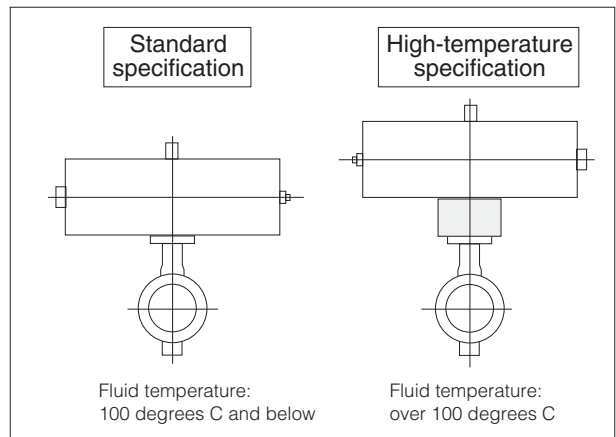

Butterfly Valve
TRITEC
TT2
334A
302A/303Q
304A/304Q
302Y/304Y
304M (HLV)
507V/508V
DTM
846T/847T/847Q
841T/842T
700Z
700G/704G/705G
700GB
731P/732P/731Q/732Q
71LG
700E/700K/700S
704G/722F/720F
KRV
227P
907H/908H (MKT)
903C

846T/847T (Wafer)/847Q (Lugged)

Single-acting Pneumatic Cylinder Type 847T-3U (Air to open: 200mm to 300mm) / 847T-3K (Air to close: 200mm to 300mm)
846T-3U (Air to open: 200mm to 300mm) / 846T-3K (Air to close: 200mm to 300mm)

847T-3U/3K Standard

Nominal size		Dimension (mm)										Cylinder type	Approx. Weight (kg)
mm	inch	ϕd	ϕD	L	H ₁	H ₂	H ₃	A	P	f ₁	f ₂		
250	10	247.5	320	68	260	260	307	1080	720	94	206	TG-12S	123
300	12	296.4	374	78	297	297	307	1080	720	94	206	TG-12S	133

847T-3U/3K Heavy Duty

Nominal size		Dimension (mm)										Cylinder type	Approx. Weight (kg)
mm	inch	ϕd	ϕD	L	H ₁	H ₂	H ₃	A	P	f ₁	f ₂		
200	8	197	266	60	220	220	307	945	585	75	165	TG-10S	66
250	10	247.5	320	68	260	260	340	1255	865	131	257	TG-14S	219
300	12	296.4	374	78	297	297	340	1255	865	131	257	TG-14S	229

846T-3U/3K Standard

Nominal size		Dimension (mm)										Cylinder type	Approx. Weight (kg)
mm	inch	ϕd	ϕD	L	H ₁	H ₂	H ₃	A	P	f ₁	f ₂		
250	10	247.5	320	68	260	260	307	1080	720	94	206	TG-12S	122
300	12	296.4	374	78	297	297	307	1080	720	94	206	TG-12S	132

846T-3U/3K Heavy Duty

Nominal size		Dimension (mm)										Cylinder type	Approx. Weight (kg)
mm	inch	ϕd	ϕD	L	H ₁	H ₂	H ₃	A	P	f ₁	f ₂		
200	8	197	266	60	220	220	307	945	585	70	165	TG-10S	66
250	10	247.5	320	68	260	260	340	1255	865	131	257	TG-14S	218
300	12	296.4	374	78	297	297	340	1255	865	131	257	TG-14S	228

Selection criteria	Standard	Select when none of the following heavy duty items apply.
	Heavy duty	Select when any of the following items apply. ① Working temperature is over 60 degrees C ② Powder or high viscosity fluids (consult us) ③ Velocity more than 3 m/s ④ Throttling ⑤ Slow travelling time of valve: more than 30 sec. ⑥ Dead end, pump outlet, emergency open

■846T/847T-3U

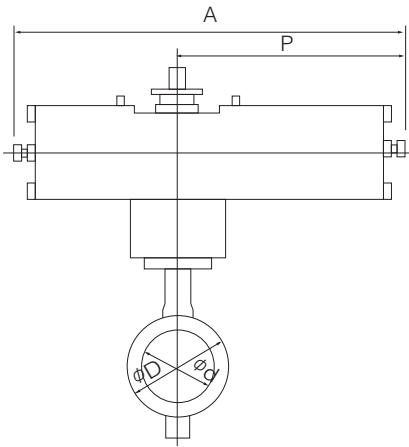

■846T/847T-3K

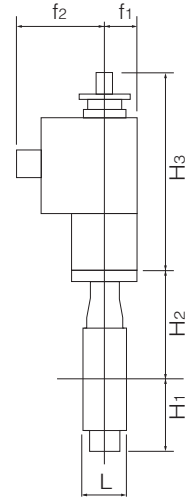
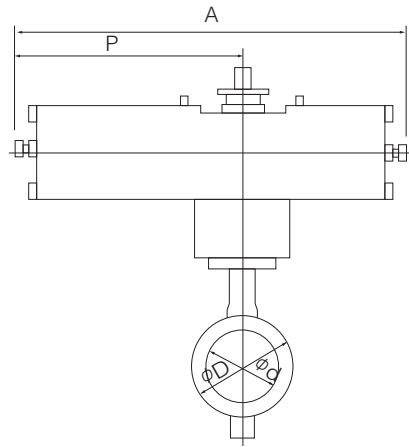

■3U Installation direction

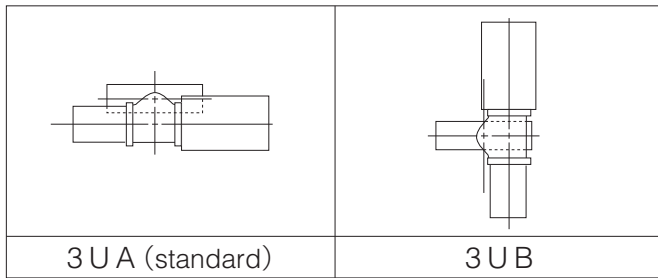

■3K Installation direction

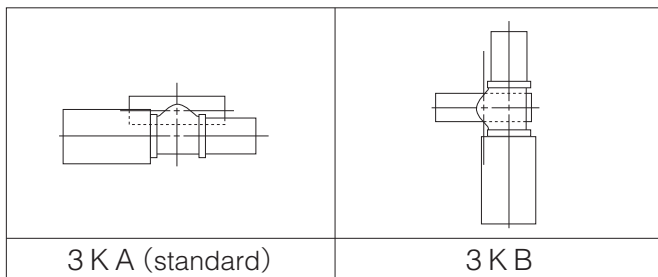

Butterfly Valve
TRITEC
TT2
334A
302A/303Q
304A/304Q
302Y/304Y
304M (HLV)
507V/508V
DTM
846T/847T/847Q
841T/842T
700Z
700G/704G/705G
700GB
731P/732P/731Q/732Q
71LG
700E/700K/700S
704G/722F/720F
KRV
227P
907H/908H (MKT)
903C

846T/847T (Wafer)/847Q (Lugged)

Single phase electric motor type 847T-4I(50mm to 300mm) / 846T-4I(65mm to 300mm)

847T-4I

Nominal size		Dimension (mm)										Motor type	Approx. Mass (kg)
mm	inch	ϕd	ϕD	L	H ₁	H ₂	H ₃	A	P	F	K		
50	2	53.4	96	43	62	118.5	150	202	100	85	54	4 I-0	6.4
65	2 1/2	67	115	46	125	125	150	202	100	85	54	4 I-0	7.5
80	3	82	131	46	132.5	132.5	165	252	138	126	65	4 I-1	10
100	4	102	152	52	148	148	165	252	138	126	65	4 I-1	11.4
125	5	127.6	190	56	171	171	198	310	167	154	85	4 I-2	20.3
150	6	151.6	217	56	183	183	198	310	167	154	85	4 I-2	22
200	8	197	266	60	220	220	198	310	167	154	85	4 I-2.5	27
250	10	247.5	320	68	260	260	230	388	223	246	136	4 I-3	52
300	12	296.4	374	78	297	297	230	388	223	246	136	4 I-3	62

847T-4I High temperature specification(SCS14 Disc: For fluids over 100 degrees C)

Nominal size		Dimension (mm)										Motor type	Approx. Mass (kg)
mm	inch	ϕd	ϕD	L	H ₁	H ₂	H ₃	A	P	F	K		
50	2	53.4	96	43	62	118.5	225	202	100	85	54	4 I-0	7.5
65	2 1/2	67	115	46	125	125	225	202	100	85	54	4 I-0	8.6
80	3	82	131	46	132.5	132.5	240	252	138	126	65	4 I-1	11.1
100	4	102	152	52	148	148	240	252	138	126	65	4 I-1	12.7
125	5	127.6	190	56	171	171	273	310	167	154	85	4 I-2	21.5
150	6	151.6	217	56	183	183	273	310	167	154	85	4 I-2	23.1
200	8	197	266	60	220	220	273	310	167	154	85	4 I-2.5	29.2
250	10	247.5	320	68	260	260	305	388	223	246	136	4 I-3	54
300	12	296.4	374	78	297	297	305	388	223	246	136	4 I-3	64

846T-4I

Nominal size		Dimension (mm)										Motor type	Approx. Mass (kg)
mm	inch	ϕd	ϕD	L	H ₁	H ₂	H ₃	A	P	F	K		
65	2 1/2	67	115	46	125	125	150	202	100	85	54	4 I-0	7.5
80	3	82	131	46	132.5	132.5	165	252	138	126	65	4 I-1	10.1
100	4	102	152	52	148	148	165	252	138	126	65	4 I-1	11.5
125	5	127.6	190	56	171	171	198	310	167	154	85	4 I-2	20.3
150	6	151.6	217	56	183	183	198	310	167	154	85	4 I-2	22
200	8	197	266	60	220	220	198	310	167	154	85	4 I-2.5	27.6
250	10	248	338	90	221	250	233	388	223	246	136	4 I-3	55
300	12	295	382	90	261	280	233	388	223	246	136	4 I-3	63

846T-4I High temperature specification(SCS14 Disc: For fluids over 100 degrees C)

Nominal size		Dimension (mm)										Motor type	Approx. Mass (kg)
mm	inch	ϕd	ϕD	L	H ₁	H ₂	H ₃	A	P	F	K		
65	2 1/2	67	115	46	125	125	225	202	100	85	54	4 I-0	8.6
80	3	82	131	46	132.5	132.5	240	252	138	126	65	4 I-1	11.2
100	4	102	152	52	148	148	240	252	138	126	65	4 I-1	12.8
125	5	127.6	190	56	171	171	273	310	167	154	85	4 I-2	21.5
150	6	151.6	217	56	183	183	273	310	167	154	85	4 I-2	23.1
200	8	197	266	60	220	220	273	310	167	154	85	4 I-2.5	28.9
250	10	247.5	320	68	260	260	305	388	223	246	136	4 I-3	54
300	12	296.4	374	78	297	297	305	388	223	246	136	4 I-3	64

■ 846T/847T-4 I

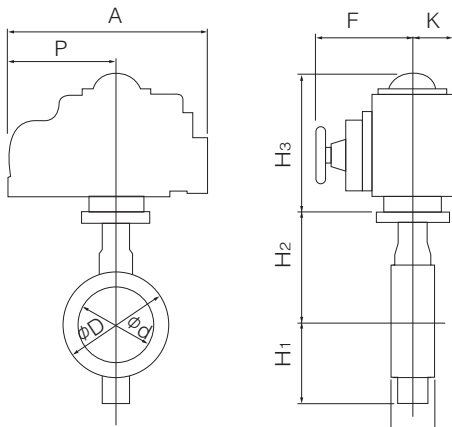

■ Caution for actuator mounting

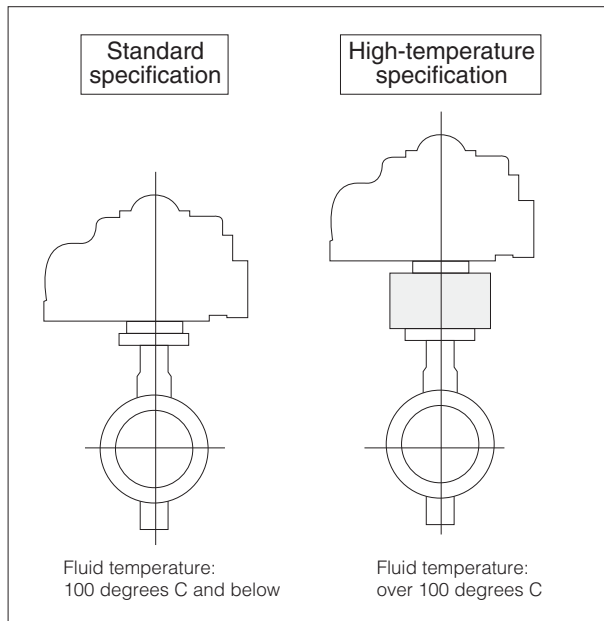

■ 4I Installation direction

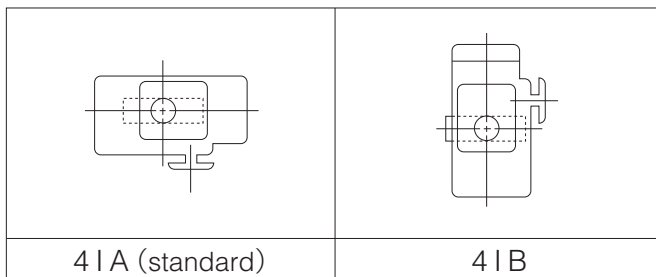

Butterfly Valve
TRITEC
TT2
334A
302A/303Q
304A/304Q
302Y/304Y
304M (HLV)
507V/508V
DTM
846T/847T/847Q
841T/842T
700Z
700G/704G/705G
700GB
731P/732P/731Q/732Q
71LG
700E/700K/700S
704G/722F/720F
KRV
227P
907H/908H (MKT)
903C

846T/847T (Wafer)/847Q (Lugged)

846T Cv value/pressure loss coefficient

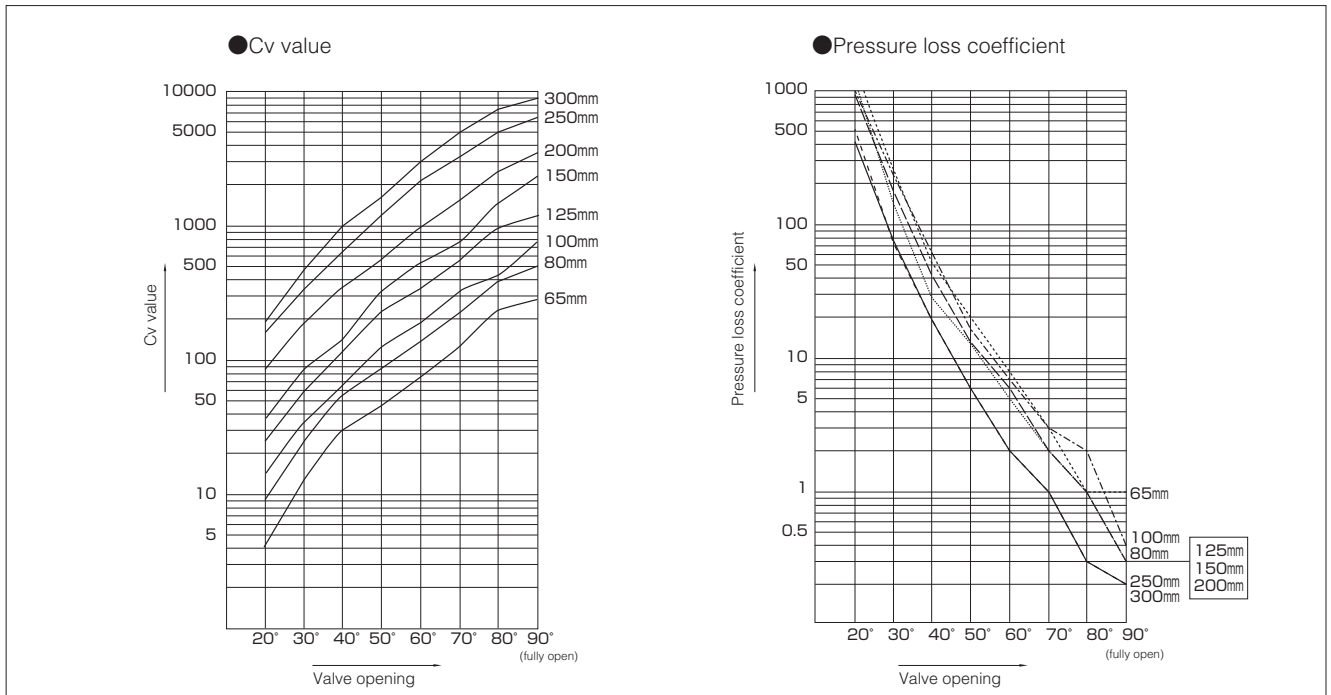

846T Cv value

Nominal size		Valve opening							
mm	inch	20°	30°	40°	50°	60°	70°	80°	90°
65	2 1/2	5	13	30	48	74	129	220	293
80	3	9	25	56	85	130	225	396	500
100	4	16	33	65	125	198	311	405	772
125	5	26	59	122	211	338	555	951	1295
150	6	37	77	145	303	507	767	1400	2166
200	8	83	178	355	592	906	1557	2573	3248
250	10	130	351	675	1225	2125	3375	5091	6200
300	12	194	487	972	1764	3011	4966	7412	8900

846T Pressure loss coefficient

Nominal size		Valve opening							
mm	inch	20°	30°	40°	50°	60°	70°	80°	90°
65	2 1/2	1829	270	51	20	8	3	1	1
80	3	1136	147	29	13	5	2	1	0.3
100	4	1015	239	62	17	7	3	2	0.4
125	5	931	181	42	14	6	2	1	0.3
150	6	901	208	59	13	5	2	1	0.2
200	8	548	119	30	11	5	2	1	0.3
250	10	528	72	20	6	2	1	0.3	0.2
300	12	488	78	20	6	2	1	0.3	0.2

847T Cv value/pressure loss coefficient

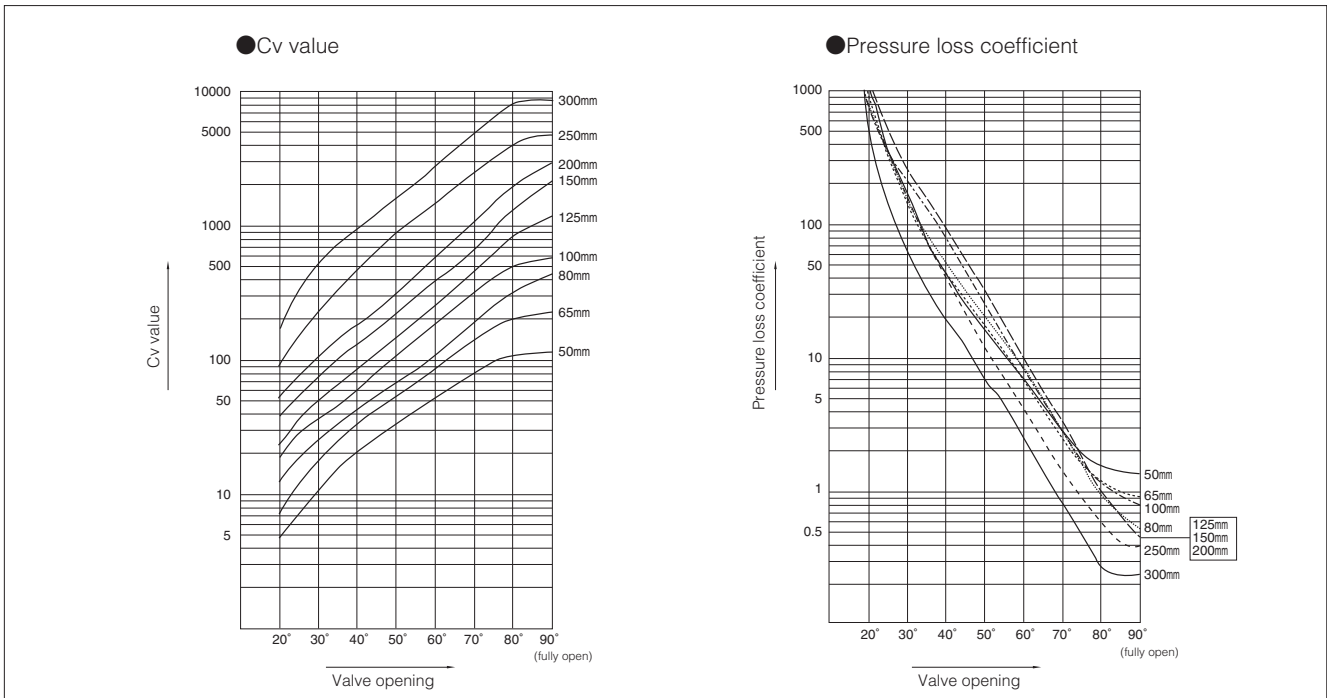

- Butterfly Valve
- TRITEC**
- TT2**
- 334A**
- 302A/303Q**
- 304A/304Q**
- 302Y/304Y**
- 304M (HLV)**
- 507V/508V**
- DTM**
- 846T/847T/847Q**
- 841T/842T**
- 700Z**
- 700G/704G/705G**
- 700GB**
- 731P/732P/731Q/732Q**
- 71LG**
- 700E/700K/700S**
- 704G/722F/720F**
- KRV**
- 227P**
- 907H/908H (MKT)**
- 903C**

847T Cv value

Nominal size		Valve opening							
mm	inch	20°	30°	40°	50°	60°	70°	80°	90°
50	2	5	10	20	32	50	78	107	114
65	2 1/2	7	18	33	51	83	140	202	229
80	3	12	25	43	67	106	184	318	428
100	4	19	35	58	103	178	309	493	585
125	5	23	49	83	141	250	441	808	1170
150	6	38	75	127	218	383	621	1260	2080
200	8	52	105	177	305	547	995	1890	2910
250	10	75	210	415	745	1250	2200	3520	4270
300	12	140	475	850	1420	2400	4190	6780	7780

847T Pressure loss coefficient

Nominal size		Valve opening							
mm	inch	20°	30°	40°	50°	60°	70°	80°	90°
50	2	675	169	42	16	7	3	1	1
65	2 1/2	933	141	42	18	7	2	1	1
80	3	639	147	50	21	8	3	1	1
100	4	720	212	77	24	8	3	1	1
125	5	1190	262	91	32	10	3	1	0.4
150	6	855	219	77	26	8	3	1	0.3
200	8	1396	342	121	41	13	4	1	0.4
250	10	1485	189	49	15	5	2	1	0.5
300	12	860	75	23	8	3	1	0.4	0.3

846T/847T (Wafer)/847Q (Lugged)

847T/846T Applicable pipe list in case of **A**

847T

Nominal size		SGP	Sch20	Sch40	VP (TS flange)	Sch10S	Sch20S	Minimum internal diameter of piping (mm)
mm	inch							
50	2	○	○	○	○	○	○	34
65	2 1/2	○	○	○	○	○	○	51
80	3	○	○	○	○	○	○	70
100	4	○	○	○	○	○	○	91
125	5	○	○	○	○	○	○	118
150	6	○	○	○	○	○	○	144
200	8	○	○	○	○	○	○	194
250	10	○	○	○	○	○	○	246
300	12	○	○	○	○	○	○	294

846T

Nominal size		SGP	Sch20	Sch40	VP (TS flange)	Sch10S	Sch20S	Minimum internal diameter of piping (mm)
mm	inch							
65	2 1/2	○	○	○	○	○	○	51
80	3	○	○	○	○	○	○	70
100	4	○	○	○	○	○	○	91
125	5	○	○	○	○	○	○	118
150	6	○	○	○	○	○	○	144
200	8	○	○	○	○	○	○	194
250	10	○	○	○	○	○	○	246
300	12	○	○	○	○	○	○	294

847T/846T Applicable pipe list in case of **B**

847T

Nominal size		SGP	Sch20	Sch40	Sch10S	Sch20S
mm	inch					
50	2	○	○	○	○	○
65	2 1/2	○	○	○	○	○
80	3	○	○	○	○	○
100	4	○	○	○	○	○
125	5	○	○	○	○	○
150	6	○	○	○	○	○
200	8	○	○	○	○	○
250	10	○	○	○	○	○
300	12	○	○	○	○	○

846T

Nominal size		SGP	Sch20	Sch40	Sch10S	Sch20S
mm	inch					
65	2 1/2	○	○	○	○	○
80	3	○	○	○	○	○
100	4	○	○	○	○	○
125	5	○	○	○	○	○
150	6	○	○	○	○	○
200	8	○	○	○	○	○
250	10	○	○	○	○	○
300	12	○	○	○	○	○

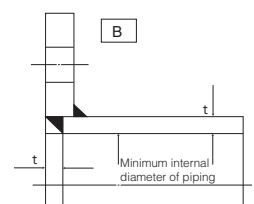
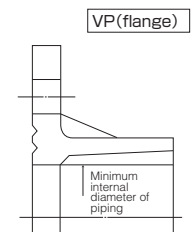
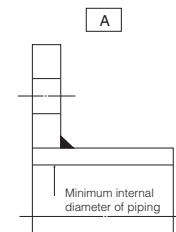

Remark 1: ○=Applicable

Remark 2: Butterfly valves are inserted into a pipe that was fitted with the disc when fully open.

In cases where you are using a pipe or flange that is less than the minimum inner pipe diameter, use is still possible if means are taken such as inserting a spacer between the valve and flange. For details, please consult us.

847T Applicable flange standard

Nominal size		JIS		ANSI		BS4504 PN10	DIN NP10	BS10 Table E
mm	inch	5K	10K	125Lb	150Lb			
50	2	○	○	○	○	○	○	○
65	2 1/2	○	○	○	○	○	○	○
80	3	D	D	D	D	D	D	D
100	4	D	D	D	D	D	D	D
125	5	D	D	D	D	D	D	D
150	6	D	D	D	D	D	D	D
200	8	D	D	D	D	D	D	D
250	10	D	D	D	D	D	D	D
300	12	D	D	D	D	D	D	D

○ : Can be used without flange drilling
D : With flange drilling

846T Applicable flange standard

Nominal size		JIS		ANSI		BS4504 PN10	DIN NP10	BS10 Table E
mm	inch	5K	10K	125Lb	150Lb			
65	2 1/2	○	○	○	○	○	○	○
80	3	D	D	D	D	D	D	D
100	4	D	D	D	D	D	D	D
125	5	D	D	D	D	D	D	D
150	6	D	D	D	D	D	D	D
200	8	D	D	D	D	D	D	D
250	10	D	D	D	D	D	D	D
300	12	D	D	D	D	D	D	D

○ : Can be used without flange drilling
D : With flange drilling

847T/ 846T Piping bolt and nut sizes

■ Piping bolts sizes

Nominal size		JIS 5K	JIS 10K	ANSI 125Lb/150Lb	DIN NP10, BS4504 PN10
mm	inch	Hexagon bolts and nuts	Hexagon bolts and nuts	Long bolts and nuts	Long bolts and nuts
50	2	4-M12× 90×30	4-M16×105×40	4-5/8-11UNC×145×45	4-M16×125×30
65	2 1/2	4-M12× 90×30	4-M16×105×40	4-5/8-11UNC×155×50	4-M16×125×30
80	3	4-M16×105×40	8-M16×110×40	4-5/8-11UNC×155×50	8-M16×130×30
100	4	8-M16×110×40	8-M16×110×40	8-5/8-11UNC×165×50	8-M16×140×35
125	5	8-M16×110×40	8-M20×120×50	8-3/4-10UNC×175×55	8-M16×140×35
150	6	8-M16×120×40	8-M20×130×50	8-3/4-10UNC×175×55	8-M20×155×40
200	8	8-M20×130×50	12-M20×135×50	8-3/4-10UNC×175×55	8-M20×160×40
250	10	12-M20×135×50	12-M22×150×60	12-7/8- 9UNC×215×55	12-M20×175×40
300	12	12-M20×150×50	16-M22×160×60	12-7/8- 9UNC×215×55	12-M20×185×40

●The bolt lengths fit the JIS or steel flanges.

Remark: ※ Use thin hexagon nuts for hexagon bolts.(Except for ANSI : nuts for ANSI is heavy nut)

※ Material: Consult us when other than SS400 (Mild steel)

Example

Long bolts: 12 - M22 × 185 × 45
N M L S

Hexagon bolts: 4 - M30 × 95 × 65
N M L S

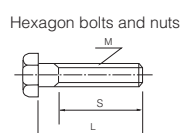
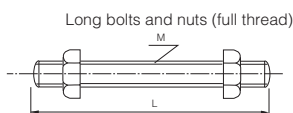

Butterfly Valve
TRITEC
TT2
334A
302A/303Q
304A/304Q
302Y/304Y
304M (HLV)
507V/508V
DTM
846T/847T/847Q
841T/842T
700Z
700G/704G/705G
700GB
731P/732P/731Q/732Q
71LG
700E/700K/700S
704G/722F/720F
KRV
227P
907H/908H (MKT)
903C